

**MOUNTAIN ST. EAST BOULEVARD SIDEWALK INSTALLATION  
REQUEST FOR QUOTATIONS**

**PROJECT DESCRIPTION** | **Location:** East boulevard of Mountain St. from 343/345/347 Mountain St. to Gilmour St. in Morden.  
**Scope of work:** Sidewalk installation incl. base works and landscaping. Site meeting can be arranged upon request.

**COMPLETION DATE** | June 30<sup>th</sup>, 2023

**FORM OF SUBMISSION** | Submissions are welcomed at the City of Morden’s main office by mail or delivered in person as follows below. Address any questions to Tatiana Sinchenko.

- **Mailing Address:**  
City of Morden Civic Center  
c/o Tatiana Sinchenko  
100-195 Stephen Street  
Morden, MB, R6M 1V3

- **Hand Delivery:**  
Civic Center or City of Morden PDO Building  
133 7<sup>th</sup> Street, Morden

Please fill in and submit the attached form by **3pm on April 18<sup>th</sup>, 2023**.

**NEGOTIATED CONTRACT** | The City may, at its discretion, enter into contract with one, multiple, or none of the parties who submit a quotation. The City is not under obligation to any party on the basis of their submission.

The City will use the proposed unit prices and proposed schedule to evaluate the bids.

Item Description		Qty.	Unit	Unit Price (\$)	Total Price (\$)
1.	Common excavation	80	YD3	\$	\$
2.	Supply and install heavy-duty non woven geotextile	150	SM	\$	\$
3.	Supply and install compacted c-base	65	YD3	\$	\$
4.	Install 1.8m wide concrete sidewalk	123	SM	\$	\$
5.	Landscaping and hydroseeding	1	LS	\$	\$
<b>SUBTOTAL</b>				\$	\$
<b>GST (5%)</b>				\$	\$
<b>TOTAL</b>				\$	\$

NOTES: 1. Contractor is responsible for disposal of all excavated material  
2. TE-8 non-woven geotextile sold by Titan or an alternative is accepted.

PROPOSED START DATE: \_\_\_\_\_

PROPOSED COMPLETION DATE: \_\_\_\_\_

Bidder Name \_\_\_\_\_

Contact Info \_\_\_\_\_

Bidder Signature \_\_\_\_\_



**MOUNTAIN STREET SIDEWALK**  
SCALE: 1:500

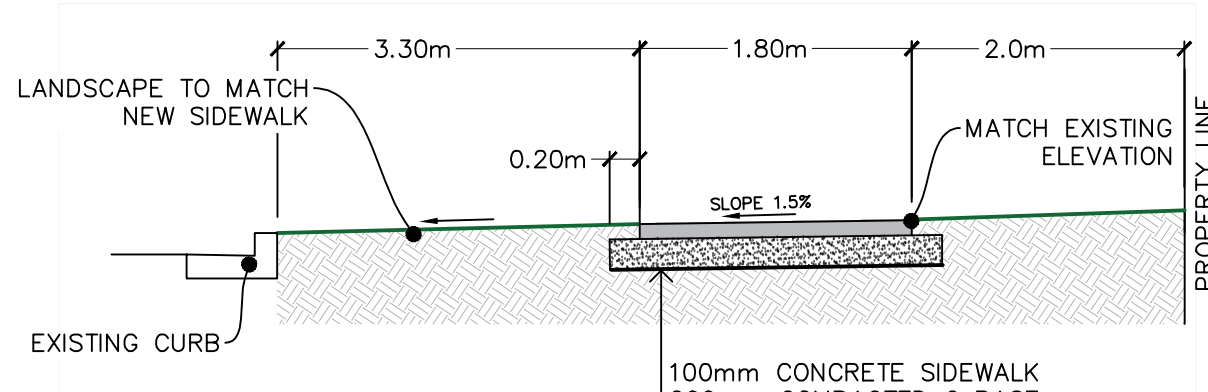

**1 CROSS SECTION**  
SCALE 1:50

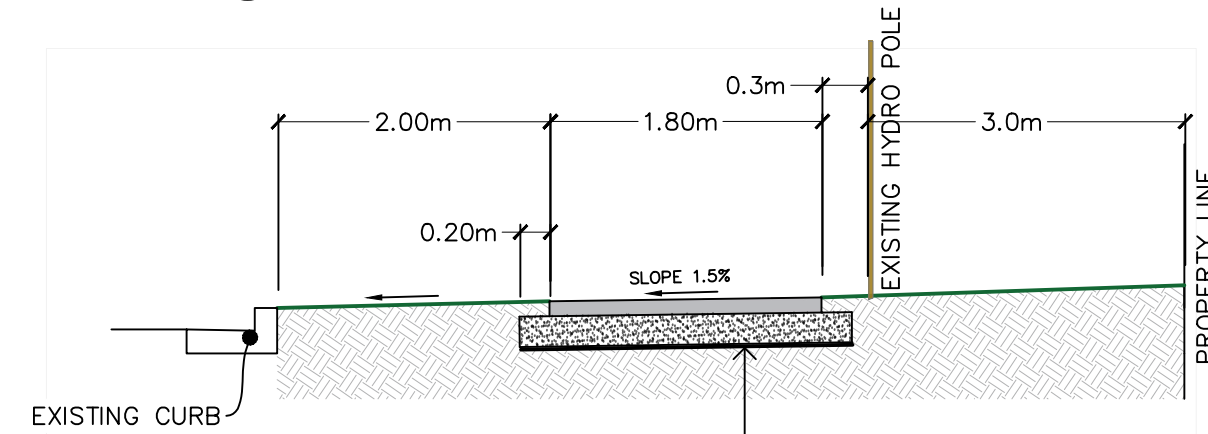

**2 CROSS SECTION**  
SCALE 1:50

NOTE: All disturbed sod must be restored by adding topsoil to match existing boulevard slope and hydroseed.



**KEY PLAN**  
SCALE: NTS

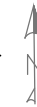

LEGEND	
	SANITARY SEWER MANHOLE
	GATE VALVE
	FIRE HYDRANT ASSEMBLY
	STORM SEWER CATCH BASIN
	PROPERTY LINE

MOUNTAIN ST. SIDEWALK

PLAN. CROSS SECTION

Date: MARCH 2023  
Drawing Scale  
**AS SHOWN**  
Project Code

Sheet Reference

**01**

R-A