

**LANDSCAPING
REQUEST FOR QUOTATIONS**

PROJECT DESCRIPTION

Location: Lakeside Cemetery is located south of Morden along the west side of highway 432 with a legal description of Lot 6, Plan 47135 within NE 36-2-6W of the RM of Stanley and a civic address of 11102 PR 432.

Scope of work: 6.2 acres requires finished landscaping, grass seed, and limestone capping of pathways over an existing base. The areas to be landscaped have been graded for drainage but will require surface rock removal, leveling, and grass seeding.

Seeding rate of 150lbs/acre. Starter fertilizer of 18-24-12 at a rate of 100lbs/acre. Surface rock removed, loaded and hauled off site. ¼ inch Limestone of 100mm compacted to 98 SPD. Additional topsoil may be required for finish grade adjacent to pathways.

Grade staking and elevations, provided by the city. Grass seed is supplied by City. of 40% red fescue, 40% Kentucky bluegrass, 20% perennial ryegrass.

COMPLETION DATE

Finished Landscaping outside of concrete runner location – May 31, 2023

Pathway completion – May 31, 2023

Finished Landscaping inside the concrete runner location – Upon completion of concrete works (Approx. July/August)

FORM OF SUBMISSION

Submissions are welcomed at the City of Morden’s main office by mail or delivered in person as follows below. Address any questions to Shawn Dias sdias@mymorden.ca or 204-362-3999.

- Mailing Address: City of Morden Civic Center
c/o Shawn Dias
100-195 Stephen Street
Morden, MB, R6M 1V3
- Hand Delivery: Parks and Urban Forestry Office
111 Gilmour St, Morden MB

NEGOTIATED CONTRACT

Please fill in and submit the attached form by **3pm on May 5th, 2023**.

The City may, at its discretion, enter into contract with one, multiple, or none of the parties who submit a quotation. The City is not under obligation to any party on the basis of their submission.

The City will use the proposed unit prices and proposed schedule to evaluate the bids.

Item Description		Qty.	Unit	Unit Price (\$)	Total Price (\$)
1.A	Limestone (1/4) Capping 2.4m wide 60m total length	30	YD	\$	\$
1.B	Limestone (1/4) Capping 1.8m wide 156m total length	50	YD	\$	\$
2.	Rock Removal and final grading	6.2	ACRE	\$	\$
3.	Seed Drilling (150lbs/ac)	6.2	ACRE	\$	\$
4.	Additional Top Soil (as needed)	10	YD	\$	\$
5.	Fertilizer supply and install (100lbs/ac)	6.2	ACRE	\$	\$
SUBTOTAL				\$	\$
GST (5%)				\$	\$
TOTAL				\$	\$

PROPOSED START DATE: _____

PROPOSED COMPLETION DATE: _____

Bidder Name _____

Contact Info _____

Bidder Signature _____

Lakeside Cemetery Location Map



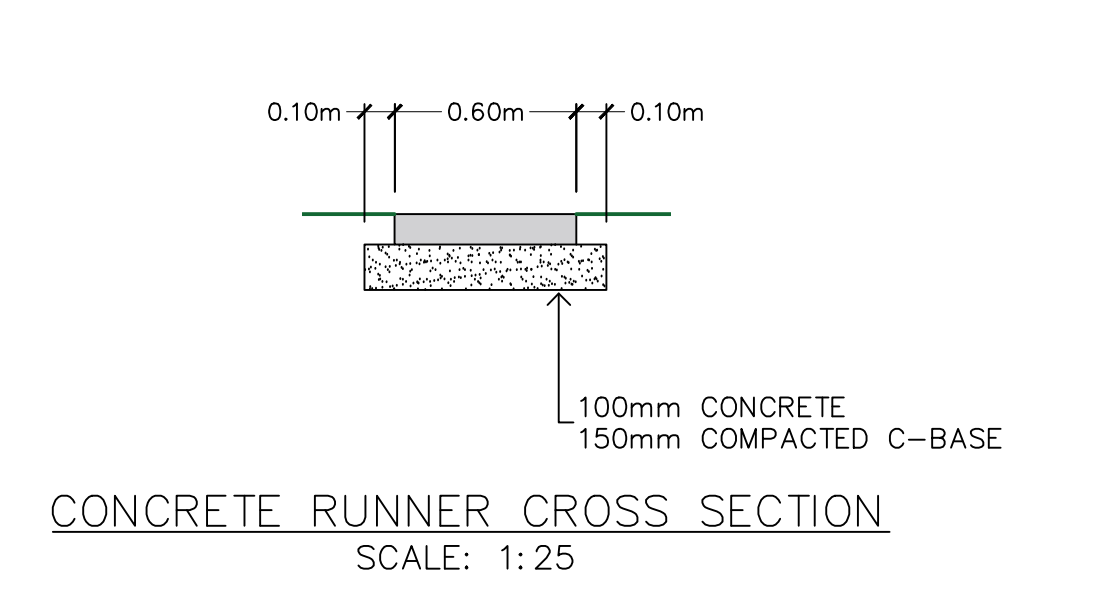
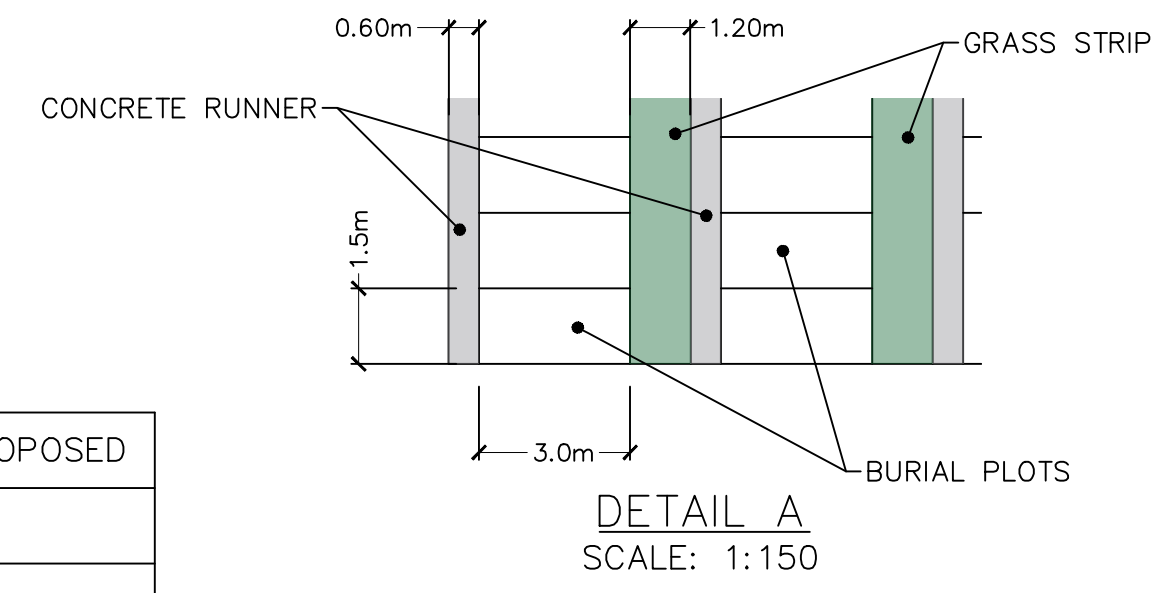
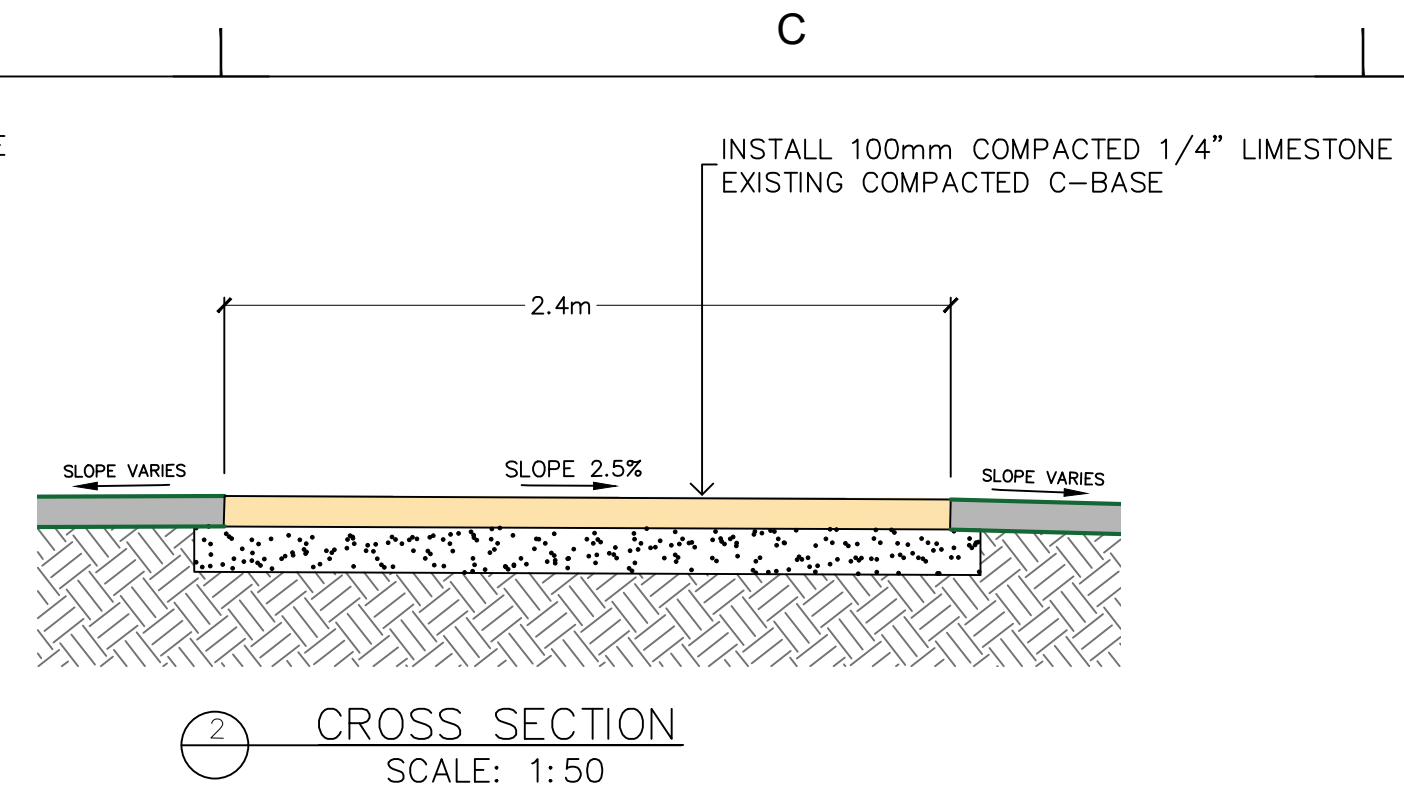
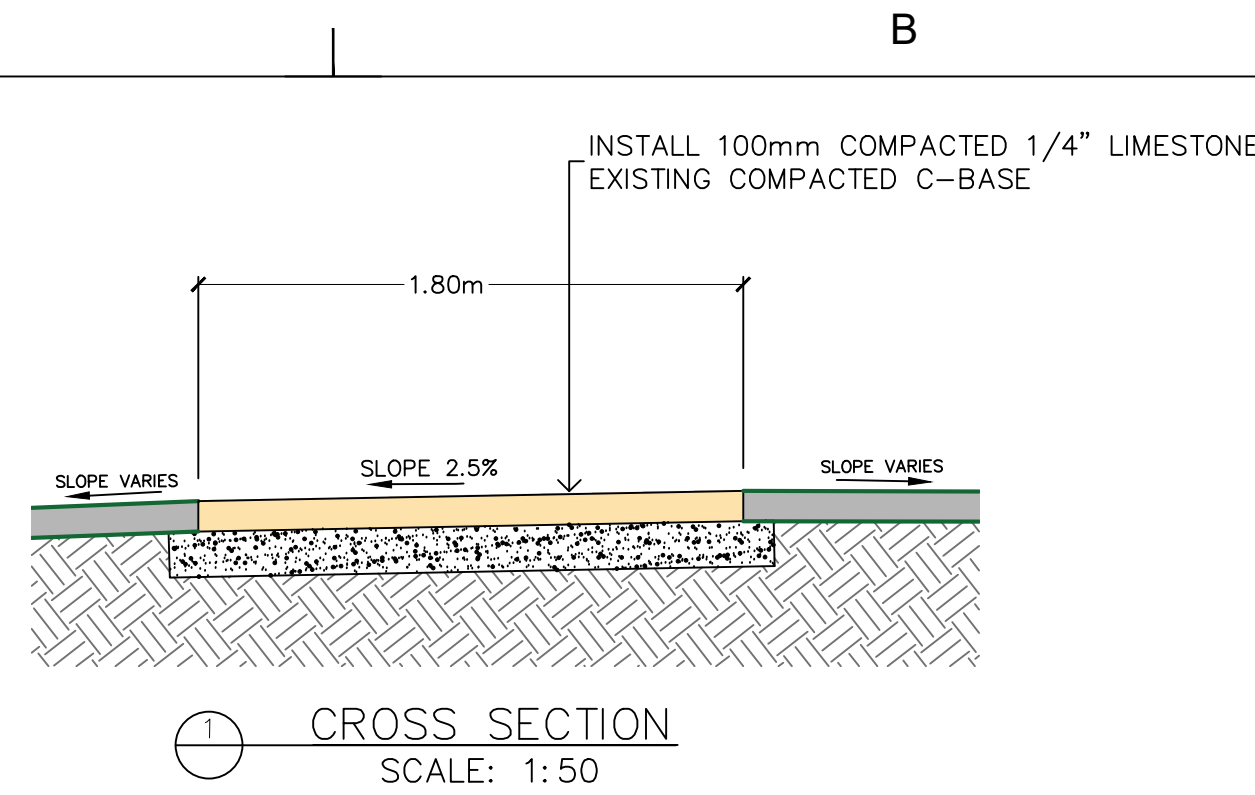
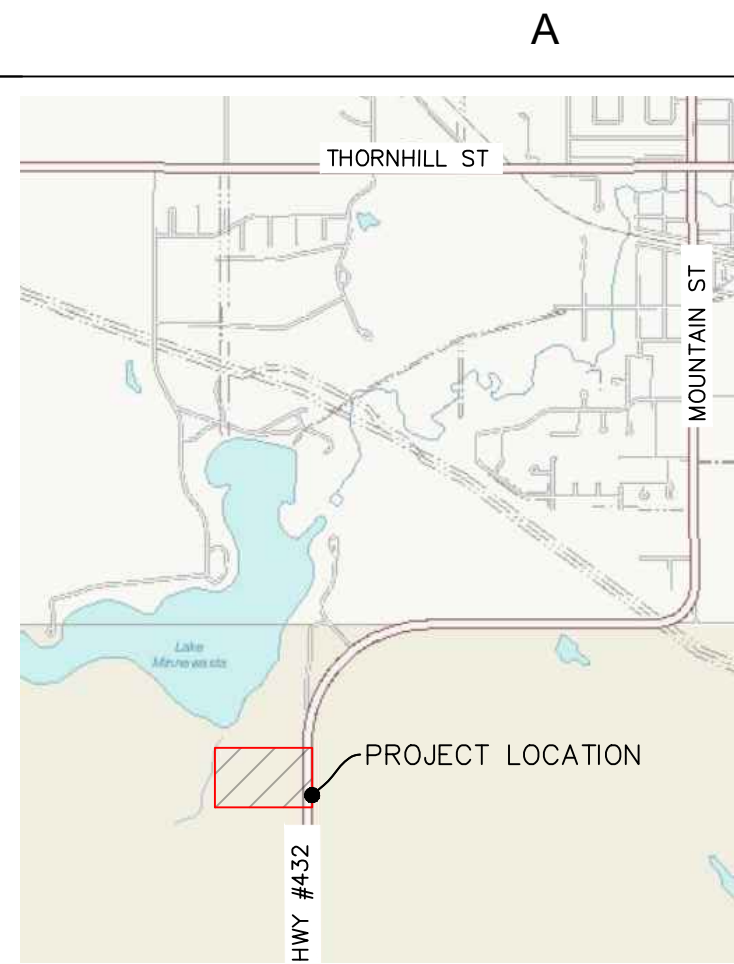

EXISTING	LEGEND-PLAN	PROPOSED
	ROAD EDGE	
	EXISTING CURB	
	DIRECTION OF SURFACE DRAINAGE	
	GROUND ELEVATION	
	PROPERTY LINE	
	LIMESTONE PATH	
	PLANTING AREA	
	PROPERTY PIN	
	DIRECTION OF TRAFFIC	

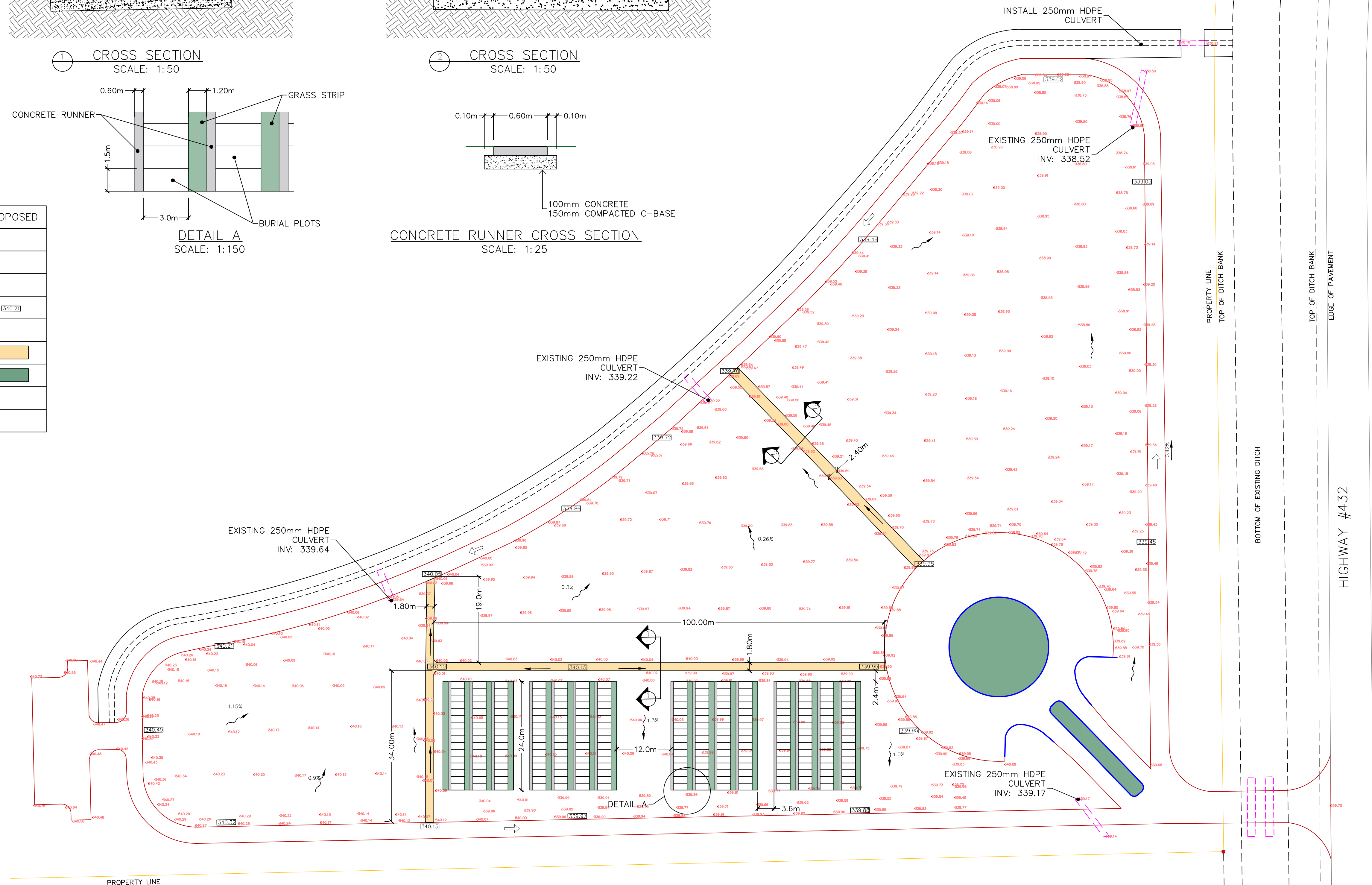

BENCHMARK IS SOUTH
EAST PROPERTY PIN
ELEVATION 339.10

CEMETERY PATHWAYS
AND LANDSCAPING

PLAN. CROSS SECTIONS

Seal

Issued

Rev.	Date	Description
Rev. A	2012/04/25	Design For Approval
Designed:	TS	MARCH 2023
Drawn:	TS	MARCH 2023
Checked:		
Approved:		

Drawing Scale
AS SHOWN

Project Code
01

Sheet Reference

X-01
R-0